

DFN DUAL FLAT NO-LEAD

DFN-8X8

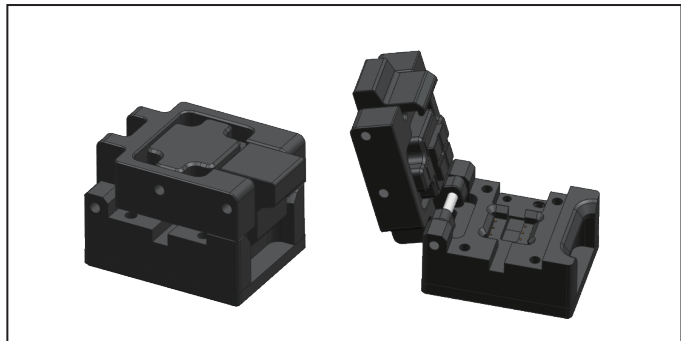

- 材质/Material
主体/Body: PEEK
接触/Contact: pogopin
镀覆/Plating: Au plating (Ni-base)
- 电特性/Electrical Characteristics
额定电流/Rated Current: 3A
绝缘电阻/Insulation Resistance: 1000mΩ min. at 500V DC
接触电阻/Contact Resistance: 100mΩ max. at 100mA max
- 其他/Others
使用温度/Operating Temperature Range: -55°C~+175°C
抗疲劳/Anti-Fatigue: 50000 cycle (因测试条件不同结果可能不同/Results may vary depending on test conditions)

产品尺寸/Product Dimensions: (长宽高/LWH, 关键封装尺寸/Critical Package Sizes, 引脚尺寸/Pin Size)

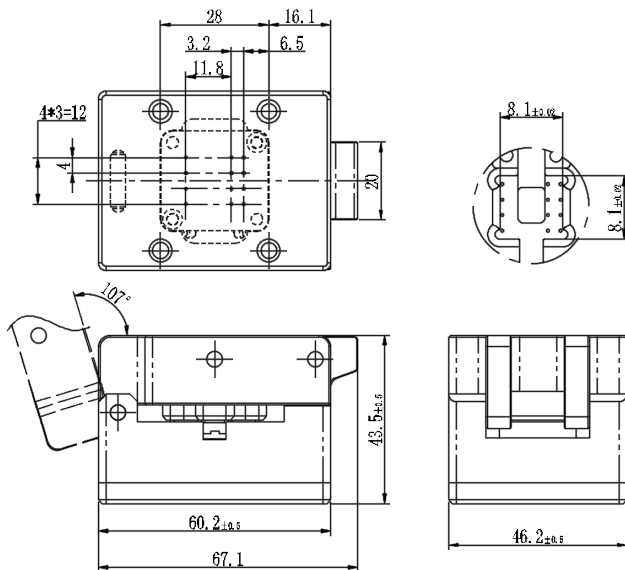

器件封装要求含/Device Packaging Requirements Including

